

TAP1500
1.5 GHz, 10X Active Probe
Instruction Manual



071-1809-00

TAP1500
1.5 GHz, 10X Active Probe
Instruction Manual

Copyright © Tektronix, Inc. All rights reserved. Licensed software products are owned by Tektronix or its subsidiaries or suppliers, and are protected by national copyright laws and international treaty provisions.

Tektronix products are covered by U.S. and foreign patents, issued and pending. Information in this publication supersedes that in all previously published material. Specifications and price change privileges reserved.

TEKTRONIX and TEK are registered trademarks of Tektronix, Inc.

Contacting Tektronix

Tektronix, Inc.
14200 SW Karl Braun Drive
P.O. Box 500
Beaverton, OR 97077
USA

For product information, sales, service, and technical support:

- In North America, call 1-800-833-9200.
- Worldwide, visit www.tektronix.com to find contacts in your area.

Warranty 2

Tektronix warrants that this product will be free from defects in materials and workmanship for a period of one (1) year from the date of shipment. If any such product proves defective during this warranty period, Tektronix, at its option, either will repair the defective product without charge for parts and labor, or will provide a replacement in exchange for the defective product. Parts, modules and replacement products used by Tektronix for warranty work may be new or reconditioned to like new performance. All replaced parts, modules and products become the property of Tektronix.

In order to obtain service under this warranty, Customer must notify Tektronix of the defect before the expiration of the warranty period and make suitable arrangements for the performance of service. Customer shall be responsible for packaging and shipping the defective product to the service center designated by Tektronix, with shipping charges prepaid. Tektronix shall pay for the return of the product to Customer if the shipment is to a location within the country in which the Tektronix service center is located. Customer shall be responsible for paying all shipping charges, duties, taxes, and any other charges for products returned to any other locations.

This warranty shall not apply to any defect, failure or damage caused by improper use or improper or inadequate maintenance and care. Tektronix shall not be obligated to furnish service under this warranty a) to repair damage resulting from attempts by personnel other than Tektronix representatives to install, repair or service the product; b) to repair damage resulting from improper use or connection to incompatible equipment; c) to repair any damage or malfunction caused by the use of non-Tektronix supplies; or d) to service a product that has been modified or integrated with other products when the effect of such modification or integration increases the time or difficulty of servicing the product.

THIS WARRANTY IS GIVEN BY TEKTRONIX WITH RESPECT TO THE PRODUCT IN LIEU OF ANY OTHER WARRANTIES, EXPRESS OR IMPLIED. TEKTRONIX AND ITS VENDORS DISCLAIM ANY IMPLIED WARRANTIES OF MERCHANTABILITY OR FITNESS FOR A PARTICULAR PURPOSE. TEKTRONIX' RESPONSIBILITY TO REPAIR OR REPLACE DEFECTIVE PRODUCTS IS THE SOLE AND EXCLUSIVE REMEDY PROVIDED TO THE CUSTOMER FOR BREACH OF THIS WARRANTY. TEKTRONIX AND ITS VENDORS WILL NOT BE LIABLE FOR ANY INDIRECT, SPECIAL, INCIDENTAL, OR CONSEQUENTIAL DAMAGES IRRESPECTIVE OF WHETHER TEKTRONIX OR THE VENDOR HAS ADVANCE NOTICE OF THE POSSIBILITY OF SUCH DAMAGES.

Table of Contents

| | |
|---|-----|
| General Safety Summary | iii |
| Service Safety Summary | iv |
| Environmental Considerations | v |
| Preface | vi |
| Documentation | vi |
| Conventions Used in This Manual..... | vi |
| Returning the Probe for Servicing | vi |
| Key Features..... | 1 |
| Installation..... | 2 |
| Connecting to the Host Instrument | 2 |
| Probe Controls and Indicators | 2 |
| Functional Check | 4 |
| Required Equipment | 4 |
| Basic Operation..... | 6 |
| Probe Head Assembly | 6 |
| Probe Input | 7 |
| Probe Offset | 7 |
| Accessories and Options | 9 |
| Using Standard Accessories..... | 9 |
| Optional Accessories | 13 |
| Options | 14 |
| Probing Principles | 15 |
| Ground Lead Length | 15 |
| Ground Lead Inductance | 15 |
| Low-inductance Grounding | 16 |
| SureFoot™ Grounding..... | 16 |
| Probe Tip Test Points | 17 |
| Probe Tip Stabilization | 17 |
| Specifications | 18 |
| Warranted Characteristics | 19 |
| Typical Characteristics | 20 |
| Nominal Characteristics..... | 23 |
| Performance Verification | 24 |
| Equipment Required | 24 |
| Equipment Setup | 25 |
| DC Gain Accuracy | 25 |
| Test Record..... | 26 |
| Maintenance | 27 |
| Error Condition | 27 |
| Replacement Parts..... | 27 |
| Index | |

General Safety Summary

Review the following safety precautions to avoid injury and prevent damage to this product or any products connected to it.

To avoid potential hazards, use this product only as specified.

Only qualified personnel should perform service procedures.

To Avoid Fire or Personal Injury

Connect and Disconnect Properly. Connect the probe output to the measurement instrument before connecting the probe to the circuit under test. Connect the probe reference lead to the circuit under test before connecting the probe input. Disconnect the probe input and the probe reference lead from the circuit under test before disconnecting the probe from the measurement instrument.

Observe All Terminal Ratings. To avoid fire or shock hazard, observe all ratings and markings on the product. Consult the product manual for further ratings information before making connections to the product.

Do not apply a potential to any terminal, including the common terminal, that exceeds the maximum rating of that terminal.

Do Not Operate Without Covers. Do not operate this product with covers or panels removed.

Do Not Operate With Suspected Failures. If you suspect that there is damage to this product, have it inspected by qualified service personnel.

Avoid Exposed Circuitry. Do not touch exposed connections and components when power is present.

Do Not Operate in Wet/Damp Conditions.

Do Not Operate in an Explosive Atmosphere.

Keep Product Surfaces Clean and Dry.

Terms in this Manual

These terms may appear in this manual:



WARNING. *Warning statements identify conditions or practices that could result in injury or loss of life.*



CAUTION. *Caution statements identify conditions or practices that could result in damage to this product or other property.*

Symbols and Terms on the Product

These terms may appear on the product:

- DANGER indicates an injury hazard immediately accessible as you read the marking.
- WARNING indicates an injury hazard not immediately accessible as you read the marking.
- CAUTION indicates a hazard to property including the product.

The following symbols may appear on the product:



Service Safety Summary

Only qualified personnel should perform service procedures. Read this *Service Safety Summary* and the *General Safety Summary* before performing any service procedures.

Do Not Service Alone. Do not perform internal service or adjustments of this product unless another person capable of rendering first aid and resuscitation is present.

Disconnect Power. To avoid electric shock, switch off the instrument power, then disconnect the power cord from the mains power.

Use Care When Servicing With Power On. Dangerous voltages or currents may exist in this product. Disconnect power, remove battery (if applicable), and disconnect test leads before removing protective panels, soldering, or replacing components.

To avoid electric shock, do not touch exposed connections.

Environmental Considerations

This section provides information about the environmental impact of the product.

Product End-of-Life Handling

Observe the following guidelines when recycling an instrument or component:

Equipment Recycling. Production of this equipment required the extraction and use of natural resources. The equipment may contain substances that could be harmful to the environment or human health if improperly handled at the product's end of life. In order to avoid release of such substances into the environment and to reduce the use of natural resources, we encourage you to recycle this product in an appropriate system that will ensure that most of the materials are reused or recycled appropriately.

The symbol shown below indicates that this product complies with the European Union's requirements according to Directive 2002/96/EC on waste electrical and electronic equipment (WEEE). For information about recycling options, check the Support/Service section of the Tektronix Web site (www.tektronix.com).



Restriction of Hazardous Substances

This product has been classified as Monitoring and Control equipment, and is outside the scope of the 2002/95/EC RoHS Directive. This product is known to contain lead, cadmium, mercury, and hexavalent chromium.

Preface

This manual describes the installation and operation of the TAP1500 active probe. Basic probe operations and concepts are presented in this manual. You can also access the Tektronix Web site for this document and other related information.

Documentation

To read about

TAP1500 Probe: First Time Operation, Functional Check, Operating Basics, Specifications, Performance Verification

In-depth oscilloscope operation, user interface help, GPIB commands

Use these documents ¹

Read this Instruction Manual.

Access the online help from the Help menu on the host instrument.

¹ To access the documentation that is installed on your instrument, click **Start** in the taskbar and select **Programs > TekApplications**.

Conventions Used in This Manual

The following icon is used throughout this manual to indicate a step sequence.



Returning the Probe for Servicing

If your probe requires servicing, you must return the probe to Tektronix. If the original packaging is unfit for use or not available, use the following packaging guidelines:

Preparation for Shipment

1. Use a corrugated cardboard shipping carton having inside dimensions at least one inch greater than the probe dimensions. The box should have a carton test strength of at least 200 pounds.
2. Put the probe into an antistatic bag or wrap it to protect it from dampness.
3. Place the probe into the box and stabilize it with light packing material.
4. Seal the carton with shipping tape.
5. Refer to *Contacting Tektronix* at the beginning of this manual for the shipping address.

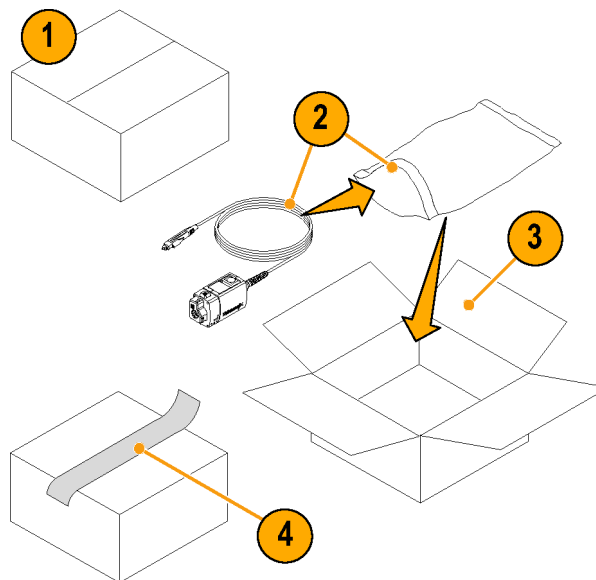

Key Features

The TAP1500 active probe enables you to make accurate measurements with minimal circuit loading from DC to 1.5 GHz, using oscilloscopes featuring the new Tektronix TekVPI oscilloscope interface. Key features include:

- DC to >1.5 GHz Bandwidth
- Risetime <267 ps
- ± 8 Volts Dynamic Range with ± 10 volt offset capability
- 1 M Ω Input Resistance
- <1 pF Input Capacitance
- 10X Attenuation
- TekVPI Interface
- Small, low-mass probe head for probing dense circuitry

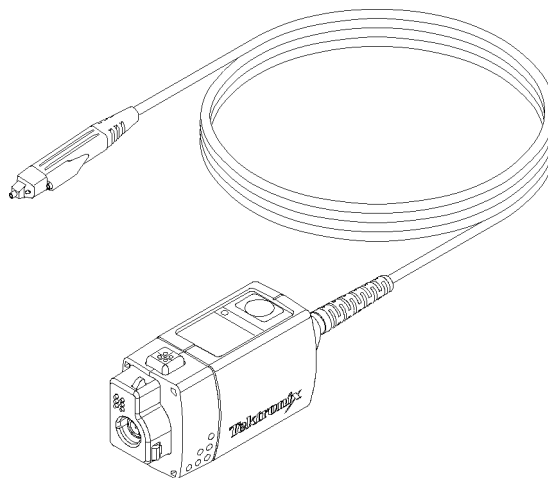

Installation

Connecting to the Host Instrument

1. Slide the probe into the TekVPI receptacle. The probe snaps when fully engaged.
When the probe is connected, the host instrument reads information from the probe and identifies the device.
2. To disconnect, press the latch release button and pull away from the instrument.

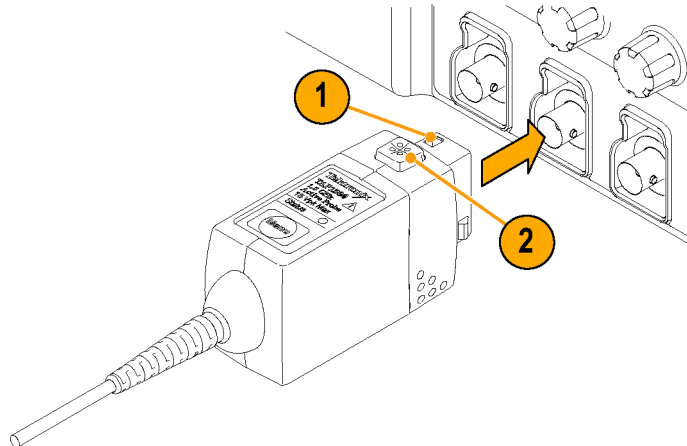

Probe Controls and Indicators

Status LED

When the probe is powered on, the multicolor Status LED:

- Glows green after successfully completing the power-on self test routine. The probe is in normal operating mode.
- Glows red if an error condition exists. (See page 27, *Error Condition*.)

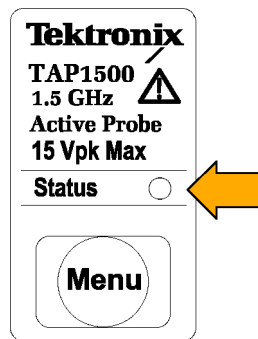

Quick Tip

If the LED does not light, and other probes are connected to the host instrument, the available probe power may be limited. Try disconnecting another probe from the instrument to reduce the load.

Menu Button

1. Press the probe **Menu** button to display the Probe Setup screen on the oscilloscope.
2. Use the buttons on the instrument to set the probe parameters.
3. Press the probe **Menu** button again to close the Probe Setup screen.

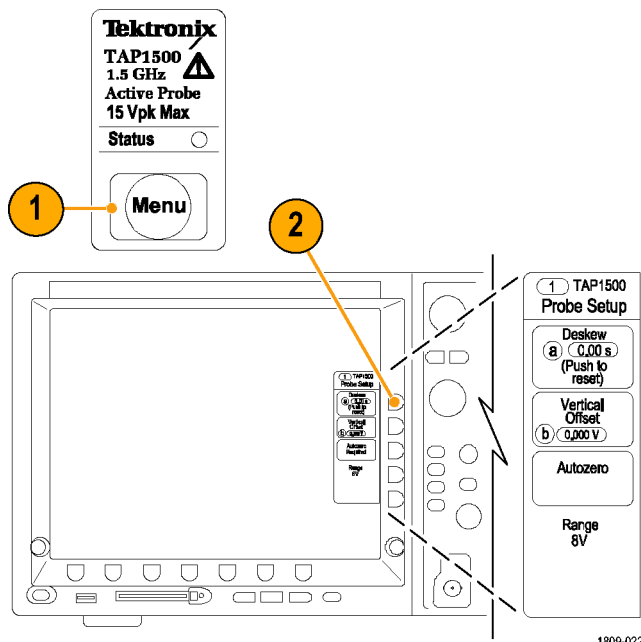

AutoZero

We recommend that you run the probe AutoZero routine:

- After the 20 minute warm-up period
- When the operating temperature of the probe changes by ± 5 °C

1. Press the probe **Menu** button to display the Probe Setup screen on the oscilloscope.
2. Short the probe tip to ground.
3. Press the **AutoZero** button on the instrument to execute the AutoZero routine.
4. Press the **Menu** button again to close the Probe Setup screen.

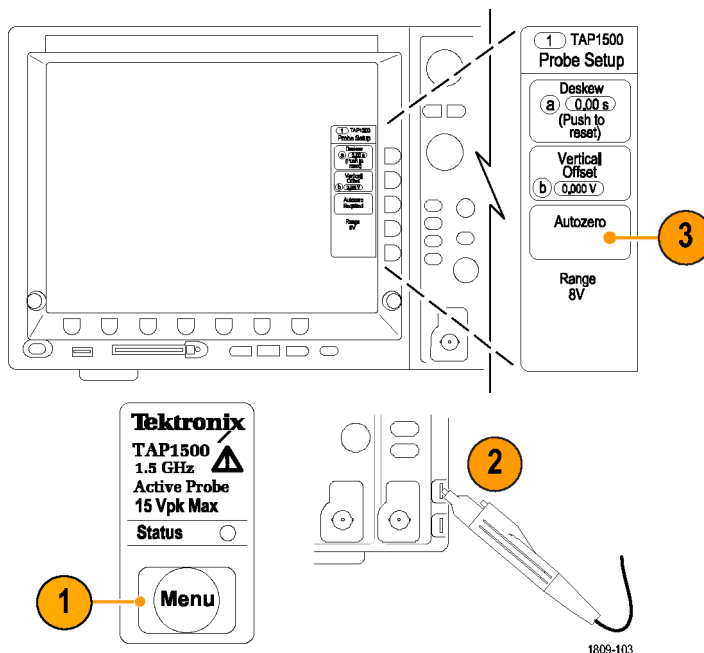

Functional Check

Use the following procedure to check that your probe is functioning properly. If you want to verify that your probe meets the warranted specifications, refer to the *Performance Verification* procedures. (See page 24, *Performance Verification*.)

Required Equipment

| Description and quantity | Performance requirement | Recommended example ¹ |
|---------------------------|--|----------------------------------|
| Oscilloscope | TekVPI Interface | Tektronix DPO4000 Series |
| Y-Lead adapter | 0.025 inch square pins for probe tip connections | 196-3463-XX ² |
| SMT KlipChip adapters (2) | 0.025 inch square pins-to-mini clips | 206-0364-XX ² |

¹ Nine-digit part numbers (xxx-xxxx-xx) are Tektronix part numbers.

² Standard probe accessory.

Signal

1. Connect the probe to any channel of the oscilloscope and set the oscilloscope to display that channel.
2. Use the Y-lead Adapter and two SMT KlipChips to connect the probe tip to the PROBE COMP terminals on the oscilloscope.
3. Press **AUTOSET** (or adjust the oscilloscope) to display the calibration waveform. A stable waveform indicates that your probe is functioning correctly.
If desired, check the probe offset function on the following page.

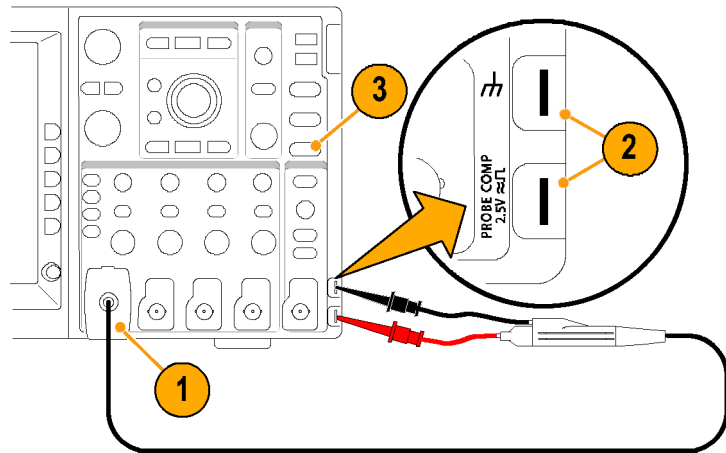

Offset

4. Disconnect the KlipChip from the PROBE COMP SIGNAL terminal and connect the KlipChip to the ground terminal.
5. Set the probe offset to 0.0 V. The oscilloscope trace goes to the ground reference. If it does not, run the Autozero routine to null out the offset error.
6. Set the oscilloscope volts/division to 5 V.
7. Adjust the probe offset. The displayed waveform should vary between approximately +10 V and -10 V. (A +10 V offset displays a -10 V level on your instrument.)

If the probe does not pass these functional checks, go to the *Troubleshooting* section of this manual.

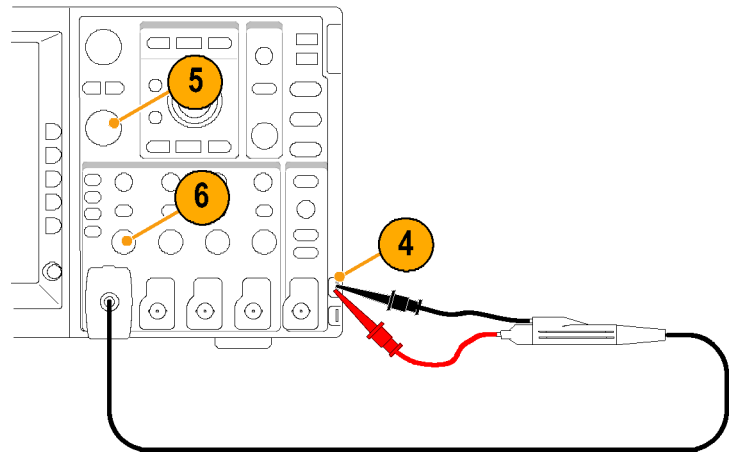

Basic Operation

Follow these operating guidelines to get optimum performance from your probe.

Probe Head Assembly

The probe head is designed for ease of use and high performance. Its small size makes it easy to handle in tight areas.

1. The probe tip socket is sized to easily press onto 0.025 inch pins for direct access.
2. The ground socket provides a short ground path for high-fidelity ground connections.
3. The stabilization notch permits you to use adjacent pins to reduce stresses on the probe and pins.

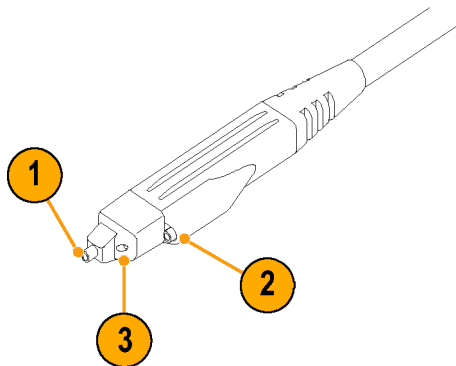

Probe Input

The probe is electrically protected against static voltage. However, applying voltages above its design limits may damage the probe tip amplifier. (See Figure 1.)

Input Linear Dynamic Range

The probe head amplifier used by the probe has a limited linear operating range. To keep the input linearity error less than 4% you must limit the signal input voltage to ± 8 V (including any DC offset).

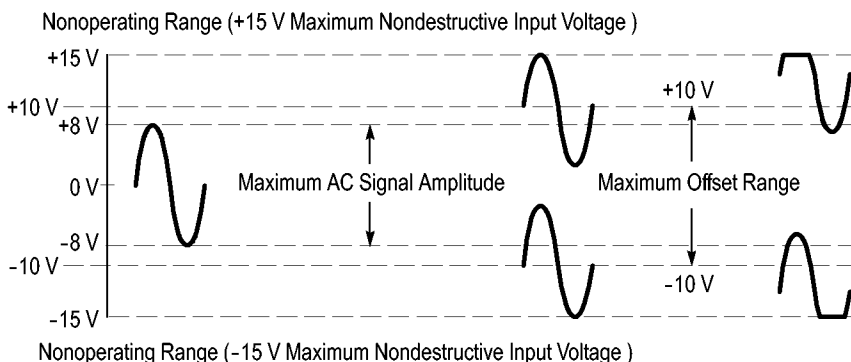

Figure 1: Dynamic and Offset Limitations

Probe Offset

The probe offset is adjustable to permit operation within the linear range of the probe, and to increase the sensitivity of the probe at higher DC measurement voltages. Using the offset to cancel DC signal components enables optimal probe performance. (See Figure 1 on page 7.)

NOTE. See your oscilloscope manual for specific instructions on its operation and offset control.

To set the probe offset, follow these steps:

1. Use the vertical position control to set a zero reference position on the oscilloscope display.
2. Set the oscilloscope coupling to **DC** and scale to **5 V/div**. This sets the oscilloscope to display the full offset dynamic range of the probe.

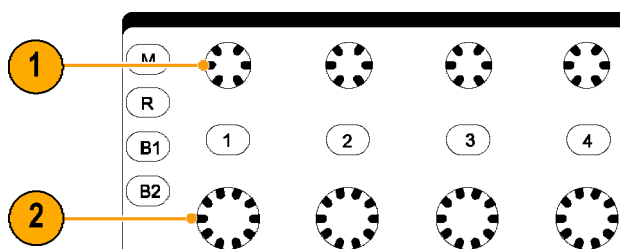

3. Attach the probe to the circuit.
4. Adjust the probe offset to bring the trace to the oscilloscope zero reference.
5. Change the volts/division setting to the desired range, adjusting the offset to keep the trace on the zero reference level.

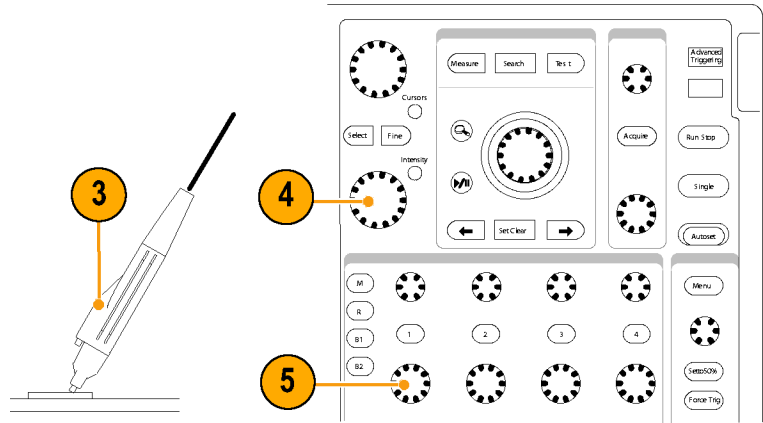

NOTE. The probe has a ± 10 V offset range. The linear operating range is ± 8 V. If cursors are used on the oscilloscope, the zero reference will be at the probe offset voltage. (See Figure 1 on page 7.)

Accessories and Options

This section lists the standard accessories and provides information on how to use the accessories. Specifications are provided where appropriate so that you can choose the accessory that best fits your needs. In some cases, reorder kit quantities differ from the actual number of accessories included with the probe.

Using Standard Accessories

Color Band Kit (Five Colored Pairs)

1. Attach one band to the probe cable and another one of the same color near the probe compensation box.
2. Connect the probe to the channel that matches the color of the band.

Reorder Tektronix part number: 016-1315-XX

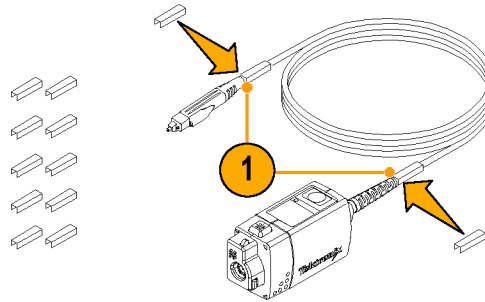

Push-in Probe Tip

Use the push-in probe tip for general purpose probing by hand. You can also use the push-in probe tip with the other socketed leads and adapters.

1. Push the tip into the socket until it is seated. Either end of the tip may be used.

Do not force the tip. Also, be careful not to injure yourself on the sharp point.

To remove the tip, *gently* grab the tip with small pliers and pull the tip out.

Reorder Tektronix part number 196-5638-XX,
qty. 10

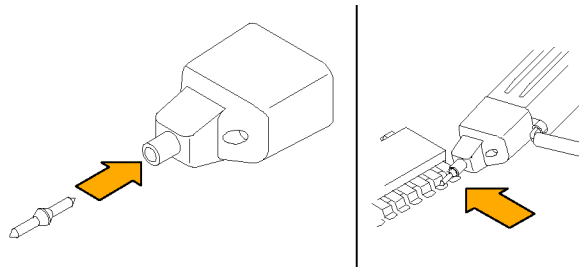

Right-Angle Adapter

Use the right-angle adapter for low-profile probing of 0.025 inch diameter square pins. The right-angle adapter allows the probe to lie flat against a circuit board, enabling you to probe in vertical circuits such as computer or communications backplanes, or in tight areas such as between circuit cards.

The right-angle adapter can be used directly with the probe head, or attached to the Y-lead adapter or ground leads.

Attach the right-angle adapter the same way as the push-in probe tip.

Reorder Tektronix part number:
214-4227-XX, qty. 1

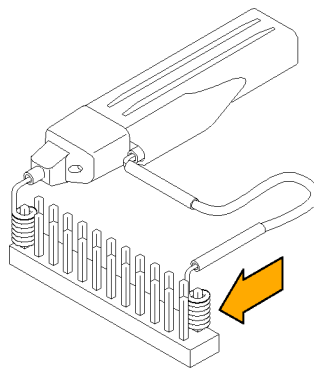

Y-Lead Adapter

Use the Y-lead adapter to extend the reach of the probe and ground. The Y-lead adapter accepts any of the probe tips or adapters, and can be pushed directly onto 0.025 inch pins.

When selecting the grounding connection, maintain as short a ground path as possible. (See page 15, *Ground Lead Length*.)

Reorder Tektronix part number:
196-3463-10, qty. 2

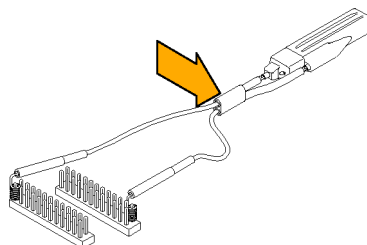

Ground Leads

Use the three- and six-inch ground leads for general, lower-frequency probing. The socketed end of the leads may be connected to any of the probe tips and adapters, or fitted onto 0.025 inch pins.

When selecting the grounding connection, maintain as short a ground path as possible. (See page 15, *Probing Principles*.)

1. Press and rotate the lead pin connector into the ground socket on the probe head.

Remove the lead by pulling the pin out by hand.

Three-inch ground leads, reorder Tektronix part number: 196-3437-10, qty. 2

Six-inch ground leads, reorder Tektronix part number: 196-3436-10, qty. 2

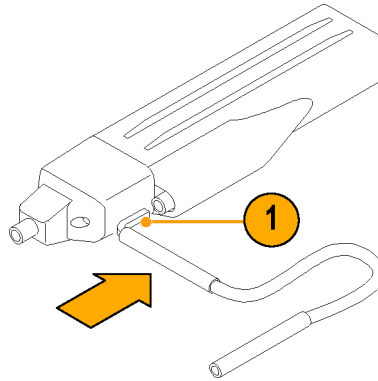

Low Inductance Ground Lead

Use the low-inductance ground lead to substantially reduce ground lead inductance. Because the ground lead simply touches the ground reference, you can easily move the probe to different points on the device under test.

To attach, press the ground lead into the probe head ground socket.

Reorder Tektronix part number: 196-3439-10, qty. 2

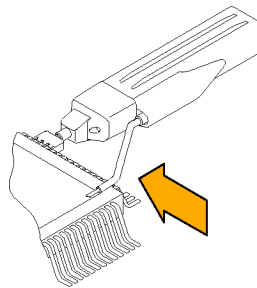

Signal-Ground Adapter

The signal-ground adapter is ideal for use with signal/ground pairs on 0.100 inch header pins. Attach the signal-ground adapter by gently pressing it into the ground socket on the probe head.

Use the stabilization notch whenever possible to avoid slipping the probe off your test point.

Reorder Tektronix part number: 131-5777-XX, qty. 1

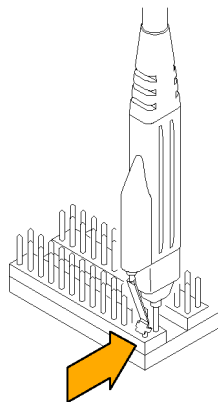

SMT KlipChip

Use the SMT KlipChip test clips to access fragile, dense circuitry. KlipChip test clips can be connected to the Y-lead or three- or six-inch ground leads. Simply press the lead socket into the KlipChip handle.

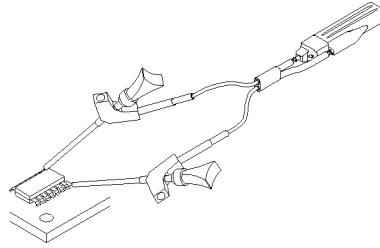

The KlipChip body freely turns, allowing better probe orientation. To reduce stress and provide a lower profile on components being tested, the flexible sleeve of the KlipChip bends up to a 35 degree angle.

Reorder Tektronix part number:

- 206-0364-XX, qty. 1
- SMG50, qty. 20

Pouch, Nylon Carrying Case with Inserts

Use the carrying case to hold the probe, the accessories, and the instruction manual.

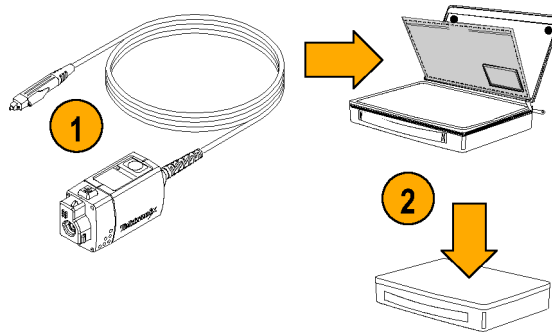

1. Place the probe, accessories, and manual in the carrying case.
2. Close the carrying case to transport the accessories to another location or for storage.

Reorder Tektronix part number: 016-1952-XX

Instruction Manual

The instruction manual provides instructions for operating and maintaining the TAP1500 active probe. Store the instruction manual in the probe case for easy reference.



Reorder Tektronix part number:

- 071-1809-XX (English)
- 071-1810-XX (Japanese)
- 071-1811-XX (Simplified Chinese)

Optional Accessories

This section lists the optional accessories that you can purchase to help you with your probing tasks.

SureFoot™ Probe Tips

The SureFoot tips are an integral probe tip and miniature guide that enables fault-free probing of fine-pitch SMD packages. Attach the SureFoot adapters the same way as the push-in probe tips.

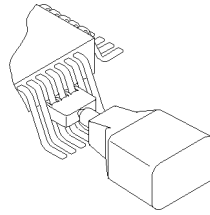

SureFoot tips are available in three sizes:

The yellow, 0.050 inch SureFoot tip is compatible with 50 mil JEDEC packages such as SOIC, PLCC, CLCC, etc.

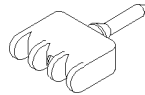

Reorder Tektronix part number SF501, qty. 12

The blue, 0.025 inch SureFoot tip is compatible with 0.65 mm JEDEC and EIAJ packages.

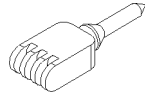

Reorder Tektronix part number SF502, qty. 12

The red, 0.5 mm SureFoot tip is compatible with EIAJ packages.

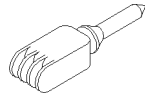

Reorder Tektronix part number SF503, qty. 12

IC Micro-Grabber

Use the IC Micro-Grabber to probe the leads on integrated circuits that are surface-mounted.

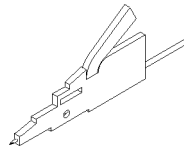

Tektronix part number: 013-0309-XX, qty. 2

Antistatic Wrist Strap

When using the probe, always work at an antistatic work station and wear the antistatic wrist strap.



Reorder Tektronix part number: 006-3415-XX

Options

Service Options

- **Option CA1.** Provides coverage for a single Calibration Event
- **Option C3.** Calibration Service 3 years
- **Option C5.** Calibration Service 5 years
- **Option D1.** Calibration Data Report
- **Option D3.** Calibration Data Report, 3 years (with Option C3)
- **Option D5.** Calibration Data Report, 5 years (with Option C5)
- **Option R3.** Repair Service 3 years
- **Option R5.** Repair Service 5 years

Manual Options

- **Option L0.** English language Instruction Manual
- **Option L5.** Japanese language Instruction Manual
- **Option L7.** Simplified Chinese language Instruction Manual

Probing Principles

Follow these helpful hints to make probing easier and noise free.

Ground Lead Length

When you are probing a circuit, you should always use as short a ground lead as possible between the probe head and circuit ground. (See the illustration for the effects of lead length on waveform distortion.)

The series inductance added by the probe tip and ground lead can result in a resonant circuit; this circuit may cause parasitic "ringing" within the bandwidth of your oscilloscope.

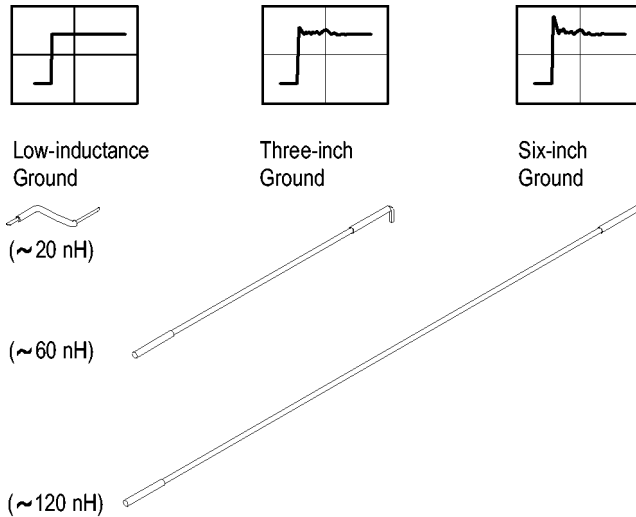

Ground Lead Inductance

When you touch your probe tip to a circuit element, you are introducing a new resistance, capacitance, and inductance into the circuit. (Refer to the illustration.)

You can determine if ground lead effects may be a problem in your application if you know the self-inductance (L) and capacitance (C) of your probe and ground lead. Calculate the approximate resonant frequency (f_0) at which this parasitic circuit will resonate with the following formula:

The preceding equation shows that reducing the ground lead inductance will raise the resonant frequency. If your measurements are affected by ringing, your goal is to lower the inductance of your ground path until the resulting resonant frequency is well above the frequency of your measurements.

The low-inductance ground contacts described in *Accessories* can help you reduce the effects of ground lead inductance on your measurements.

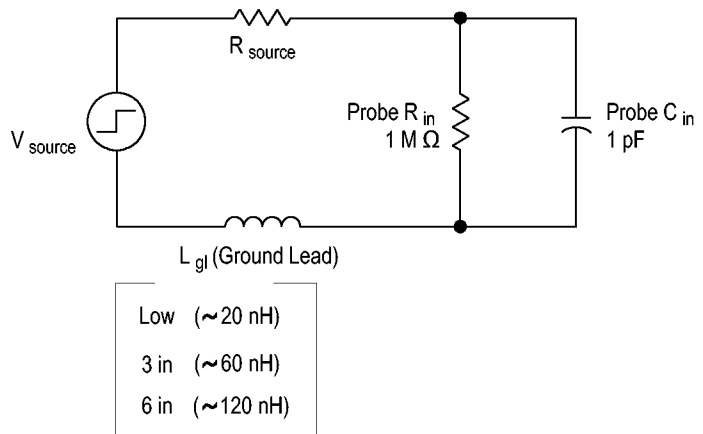

$$f_0 = \frac{1}{2\pi\sqrt{LC}}$$

Low-inductance Grounding

Use a ground plane on the package to make probing the package easier, and to avoid adding unnecessary ground lead length and distortion:

1. Attach a small piece of copper clad on top of the package.
2. Connect the copper clad to the package ground connection.
3. Use the low-inductance ground lead to keep the ground lead length as short as possible.

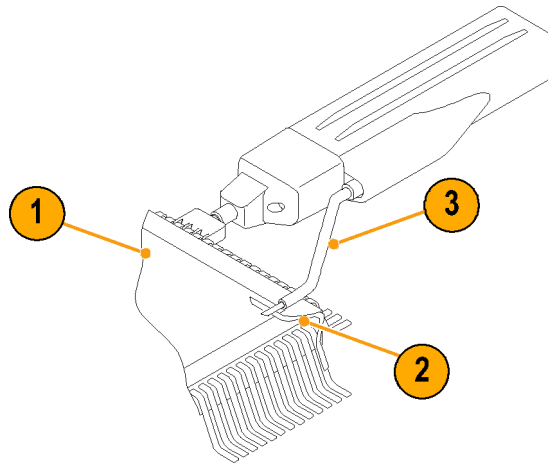

Quick Tip

This method is very useful when making many measurements on the same package.

SureFoot™ Grounding

If you cannot use the low-inductance grounding method recommended, the probe may be grounded to the package under test using a SureFoot adapter.

1. Connect a short ground lead to the probe.
2. Attach a SureFoot adapter at the end of the ground lead.
3. Connect the SureFoot adapter directly to the package ground.

This method is preferred over using an adjacent circuit ground because it is the shortest ground path possible.

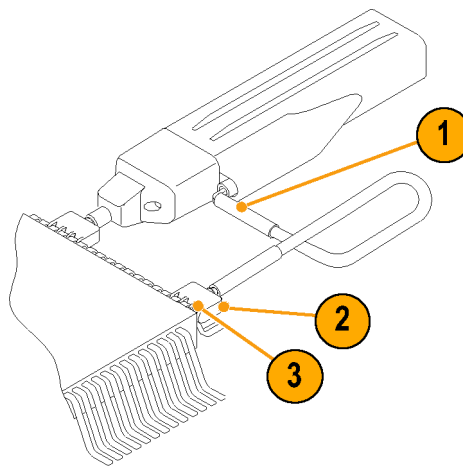

Probe Tip Test Points

The push-in probe tip or a 0.025 square pin can be soldered into a circuit to be used as a temporary test point:

1. Solder the tip onto a lead or pin with a low-power soldering iron.
2. Press the probe head onto the tip to make a measurement.
3. Pull the probe head off when you are done.

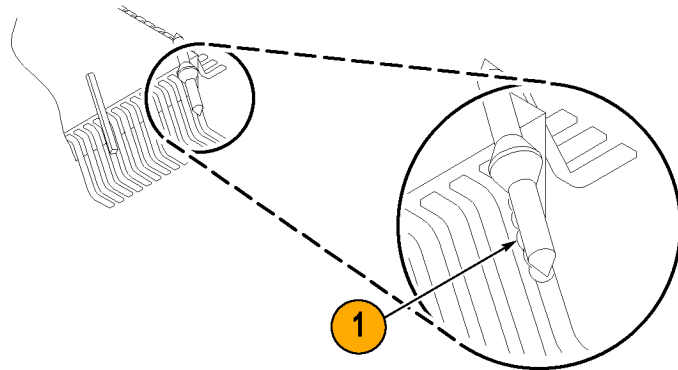

Quick Tip

The probe tip may be removed and reused by desoldering it from the circuit, and soldering it into another circuit in the future.

NOTE. Do not use pieces of solid-core copper wire as test points. If the wire breaks off in the probe tip socket, it may be impossible to remove the wire, and it will prevent insertion of other accessory tips.

Probe Tip Stabilization

The probe head has a stabilizing notch for use with 0.100 inch-spaced header pins:

1. Press the probe onto the header pin.
2. Insert the stabilizing notch of the probe onto an adjacent pin. This prevents unnecessary force from being applied directly to the probe tip or pins.

The signal-ground adapter can rest on the stabilized pin without a risk of its moving out of place.

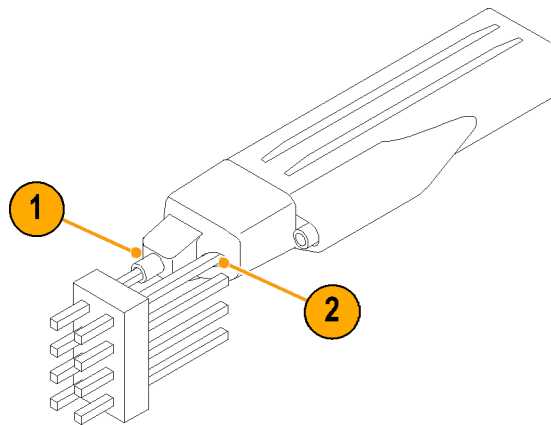

Specifications

The specifications are valid under the following conditions:

- The probe has been calibrated at an ambient temperature of $23\text{ }^{\circ}\text{C} \pm 5\text{ }^{\circ}\text{C}$.
- The probe is connected to a host instrument with an input impedance of $50\ \Omega$.
- The probe and oscilloscope must have a warm-up period of at least 20 minutes and be in an environment that does not exceed the limits described. (See Table 1.)
- The Signal Path Compensation (SPC) has been run on the oscilloscope prior to testing the probe specifications.

Specifications for the TAP1500 active probe fall into three categories: warranted, typical, and nominal characteristics.

Warranted Characteristics

Warranted characteristics describe guaranteed performance within tolerance limits or certain type-tested requirements. Warranted characteristics that have checks in the *Performance Verification* section are marked with the ✓ symbol.

Table 1: Warranted electrical characteristics

| Characteristic | Description |
|---------------------------|---|
| ✓ DC attenuation accuracy | 10:1 ±2% |
| Temperature | Operating: 0 to +50 °C (+32 to +122 °F), Nonoperating: -40 to +71 °C (-40 to +160 °F) |
| Humidity | Operating: 5-95% RH, tested up to +30 °C (+86 °F) 5-85% RH, tested at +30 °C to +50 °C (+86 to +122 °F) Nonoperating: 5-95% RH, tested up to +30 °C (+86 °F) 5-85% RH, tested at +30 °C to +75 °C (+86 to +167 °F) |
| Altitude | Operating: Up to 4400 meters (15000 feet), Nonoperating: Up to 12192 meters (51,594 feet) |

Typical Characteristics

Typical characteristics describe typical but not guaranteed performance.

Table 2: Typical electrical characteristics

| Characteristic | Description |
|---------------------------------------|--|
| Bandwidth | DC to ≥ 1.5 GHz (probe only) |
| Rise time | ≤ 267 ps (probe only) |
| Input resistance | 1 M Ω |
| Input capacitance | ≤ 1.0 pF |
| Input signal range | -8.0 V to +8.0 V |
| Input offset range | -10.0 V to +10.0 V |
| Maximum non destructive input voltage | ± 15 V _(DC + peak AC) |
| Linearity | $\pm 4\%$ or less of dynamic range |
| Output Zero | ± 10 mV or less displayed on screen with TekVPI interface at full range |
| DC offset drift | 100 mV/ $^{\circ}$ C or less displayed on screen with TekVPI interface at full range |
| Signal delay | 5.3 ns \pm 0.2 ns |

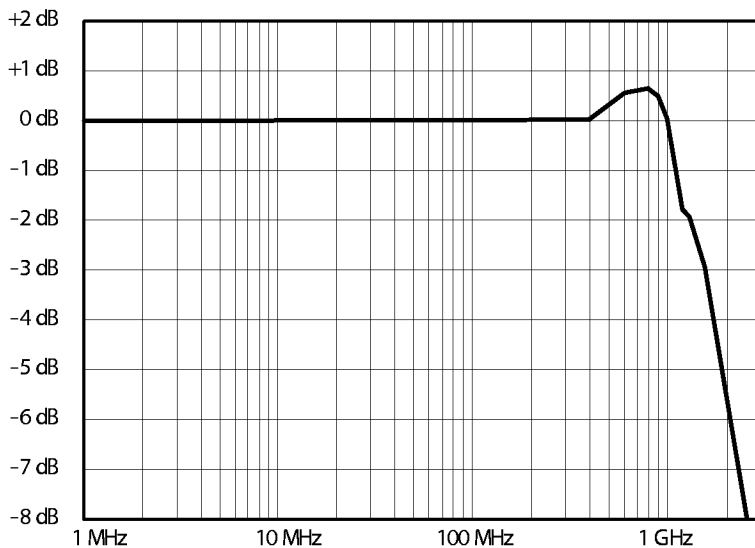

Figure 2: Typical Bandwidth

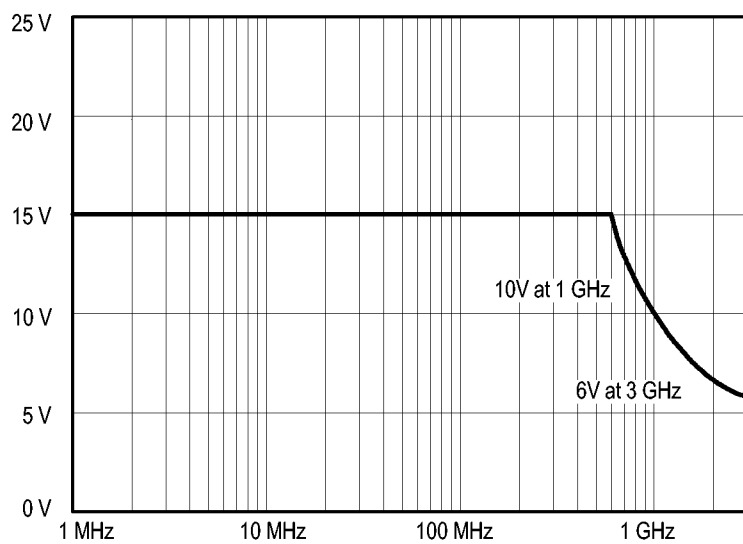

Figure 3: Typical Non-Destructive Peak Voltage Derating versus Frequency

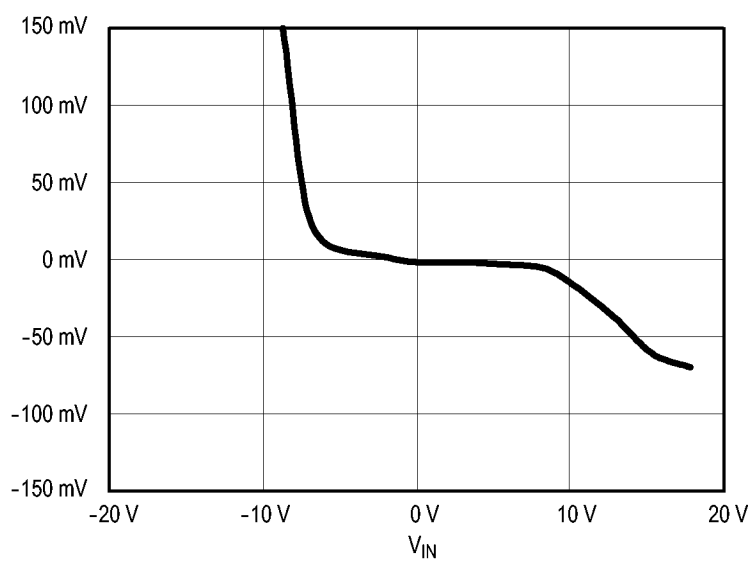

Figure 4: Typical Linearity Error versus V_{IN}

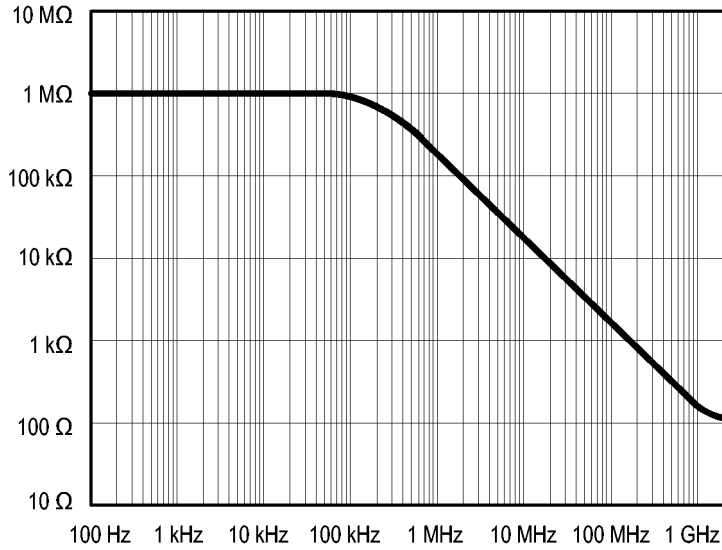

Figure 5: Typical Input Impedance versus Frequency

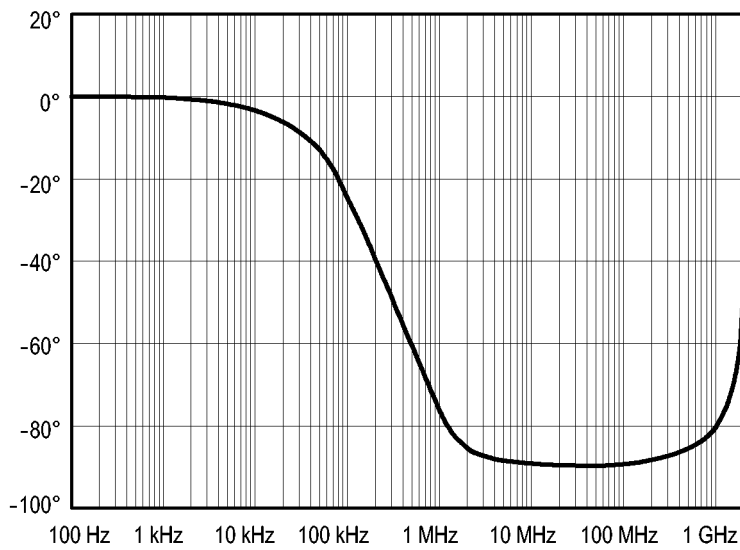

Figure 6: Typical Phase versus Frequency

Table 3: Typical mechanical characteristics

| Characteristic | Description |
|------------------------------|--|
| Dimensions, compensation box | 107 mm × 41 mm × 26 mm (4.2 in × 1.6 in × 1.0 in) |
| Dimensions, probe head | 19.43 mm × 3.30 mm × 7.6 mm (0.765 in × 0.130 in × 0.300 in) |

Table 3: Typical mechanical characteristics (cont.)

| Characteristic | Description |
|--------------------------|---|
| Dimensions, cable length | 1.3 m (51 in) (from the probe head to the compensation box) |
| Unit weight | 0.45 kg (1.0 lbs) (probe, accessories and packaging) |

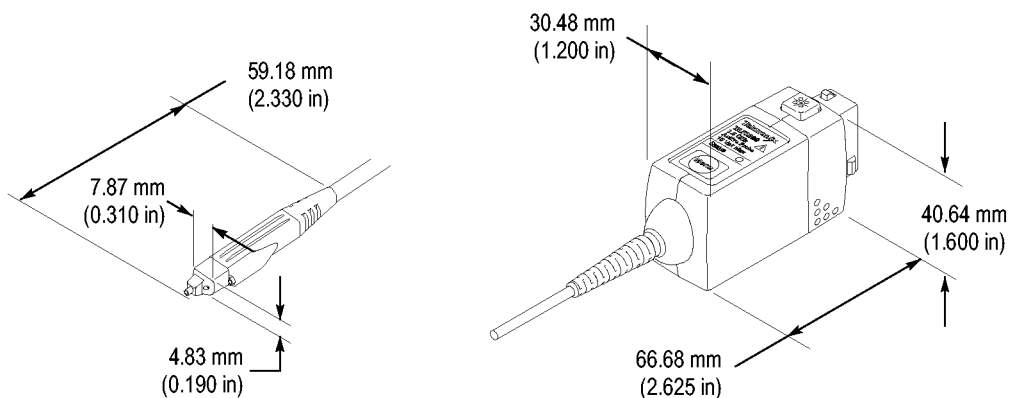

Nominal Characteristics

Nominal characteristics describe guaranteed traits, but the traits do not have tolerance limits.

Table 4: Nominal electrical characteristics

| Characteristic | Description |
|----------------|--|
| Input coupling | DC |
| Termination | Terminate output into 50 Ω |
| Compatibility | Oscilloscopes equipped with the TekVPI interface |

Performance Verification

The procedures that follow verify the warranted specifications of the probe. The recommended calibration interval is one year. Perform the verification procedures in the order listed.

Equipment Required

The following equipment is required for the performance verification procedures.

Table 5: Test equipment

| Description and quantity | Performance requirement | Recommended example ¹ |
|---|---|----------------------------------|
| Oscilloscope | TekVPI Interface | Tektronix DPO7000 Series |
| TekVPI Calibration/Verification adapter | TekVPI Interface | 067-1701-XX |
| DC voltage source | -1.0 to +1.0 VDC, 0.2% accuracy | Wavetek 9100 |
| Digital multimeter (DMM) | Resistance, 0.1% accuracy | Keithley 2700 |
| SMA M-to-BNC F adapter | SMA male-to-BNC female | 015-0554-00 |
| BNC-to-dual banana adapter (2) | | 103-0090-00 |
| BNC cable | 50 Ω , 0.76 m (30 in) length | 012-0117-00 |
| Precision termination | 50 Ω , 0.1%, 0.5W | 011-0129-00 |
| Y-Lead adapter | 0.25-in square pins for probe tip connections | 196-3463-xx ² |
| SMT KlipChip adapters (2) | 0.25-in square pins-to-mini clips | 206-0364-xx ² |

¹ Nine-digit part numbers (xxx-xxxx-xx) are Tektronix part numbers.

² Standard accessories included with the probe.

Equipment Setup

Use the following procedure to set up and warm up the equipment to test the probe.

1. Turn on the oscilloscope.
2. Connect the TekVPI Calibration/Verification adapter to the oscilloscope.
3. Connect the probe to the TekVPI Calibration/Verification adapter and verify that the Status LED on the probe turns green.
4. Turn on the remaining test equipment.
5. Allow 20 minutes for the equipment to warm up.
6. Photocopy the test record and use it to record the test results. (See page 26, *Test Record*.)

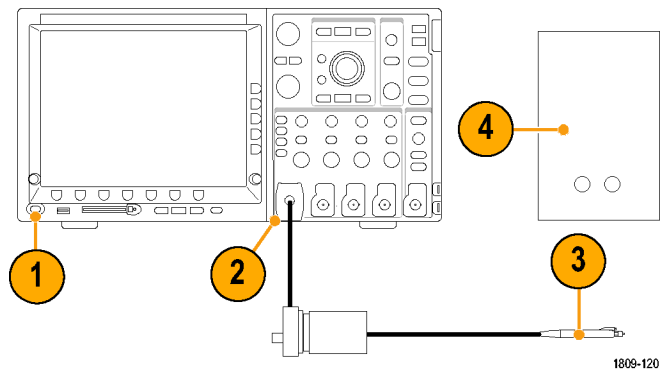

DC Gain Accuracy

This test checks the DC gain accuracy of the probe.

1. Connect the BNC-to-dual banana adapter to the DMM input.
2. Connect the SMA M-to-BNC F adapter to the SMA output of the TekVPI Calibration/Verification adapter.
3. Connect the precision termination to the BNC end of the SMA M-to-BNC F adapter.
4. Connect the BNC cable between the precision termination and the BNC-to-dual banana adapter attached to the DMM.

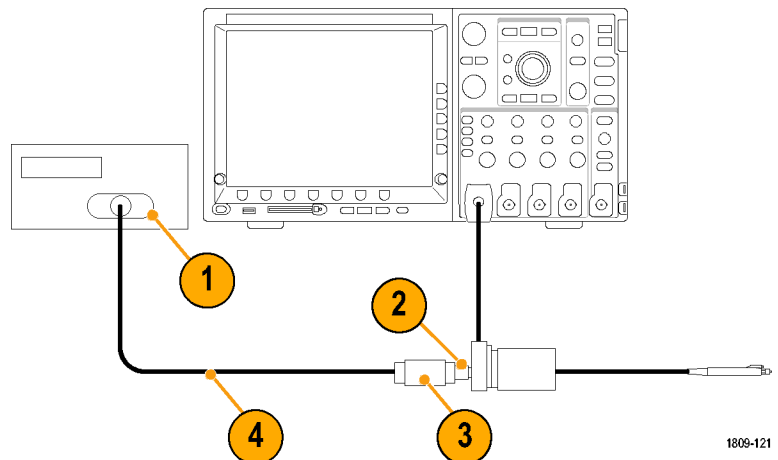

5. Connect the second BNC-to-dual banana adapter to the output of the DC voltage source.
6. Connect the Y-lead adapter and KlipChip adapters to the probe input.
7. Attach the KlipChip adapters to the BNC-to-dual banana adapter connected to the DC voltage source. Make sure the polarity is correct-ground to outer shield and probe input to center conductor.

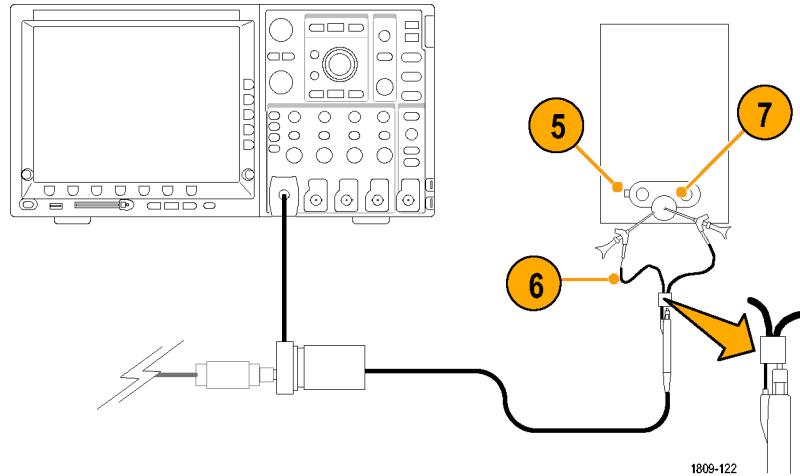

8. Set oscilloscope probe offset to 0.0 V.
9. Set the DMM to DCV.
10. Set the DC voltage source to +1.00 VDC and enable the output.
11. Record the DMM measurement in the test record.
12. Set the DC voltage source to -1.00 VDC.
13. Record the DMM measurement in the test record.

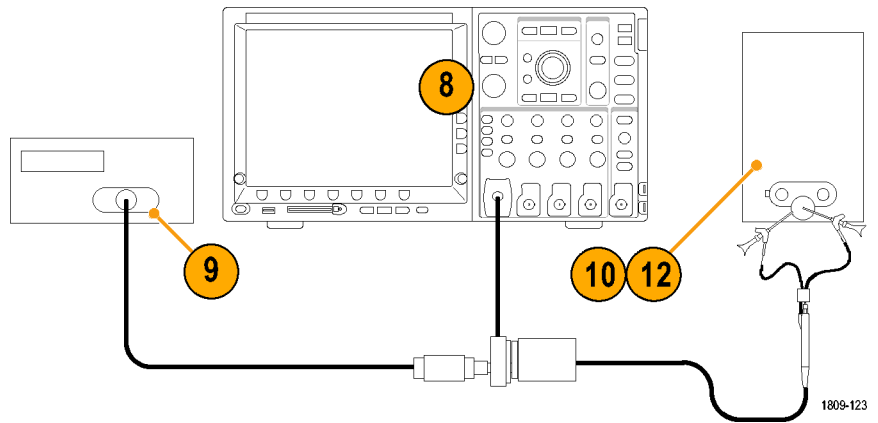

NOTE. An unacceptable error value may result if a precision 50 Ω termination is not used for the recommended termination, or if the oscilloscope probe offset is not set to zero.

Test Record

Probe Model/Serial Number:
 Temperature:
 Date of Calibration:

Certificate Number:
 RH %:
 Technician:

| Performance test | Source voltage | Minimum | Measured | Calculated | Maximum |
|------------------|----------------|---------|----------|------------|---------|
| DC Gain | +1.00 VDC | +98 mV | | NA | +102 mV |
| Accuracy | -1.00 VDC | -102 mV | | NA | -98 mV |

Maintenance

This section contains maintenance information for your probe.

Error Condition

The TAP1500 active probe is designed to work with all TekVPI-interface oscilloscopes and adapters. However, there may be some cases where all of the probe features may not work properly.

If the Status LED glows red during or after probe power on, an internal probe diagnostic fault exists. Disconnect and reconnect the probe to restart the power-on diagnostic sequence. If the Status LED continues to glow red, the probe is defective, and must be returned to Tektronix for repair.

Replacement Parts

There are no user replaceable parts within the probe. Refer to *Accessories* for a list of replaceable accessories for your probe.

Cleaning

Protect the probe from adverse weather conditions. The probe is not waterproof.



CAUTION. *To prevent damage to the probe, do not expose it to sprays, liquids, or solvents. Avoid getting moisture inside the probe during exterior cleaning.*

Do not use chemical cleaning agents; they may damage the probe. Avoid using chemicals that contain benzine, benzene, toluene, xylene, acetone, or similar solvents.

Clean the exterior surfaces of the probe with a dry, lint-free cloth or a soft-bristle brush. If dirt remains, use a soft cloth or swab dampened with a 75% isopropyl alcohol solution. A swab is useful for cleaning narrow spaces on the probe, use only enough solution to dampen the swab or cloth. Do not use abrasive compounds on any part of the probe.

Index

A

Accessories
 optional, 13
 standard, 9
Autozero, 3

C

Cleaning the probe, 28
Connecting the probe, 2

D

DC gain accuracy
 performance check, 25
Documentation, vi

E

Error condition, 27

F

Features, 1
Functional check, 4

G

Ground lead
 inductance, 15
 selecting length, 15

I

Indicators, 2

L

LED
 Status, 2

M

Maintenance, 27
Menu Button, 3

O

Offset, 7
Options, 14

P

Performance verification, 24
 equipment required, 24
 equipment setup, 25
Probe controls and indicators, 2
Probe head, 6

R

Related documentation, vi
Replacement parts, 27

S

Safety Summary, iii
Specifications, 18
 nominal, 23
 typical, 20
 warranted, 19
Status LED, 2, 27

T

TekVPI, 2
Test record, 26